



Series 940

Handheld Stand & Puck

The new PODs Series 940... the easiest to use security system in the world

- Long stretch, long life, low maintenance cord
- Lock-in power connector
- Transition mounting in seconds
- Patented IR Technology allows store-specific key coding
- Independent alarming security for every display position

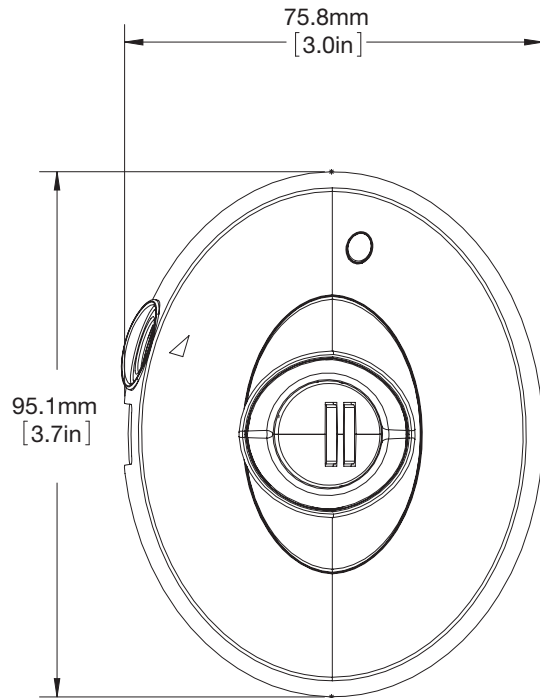

EC9102

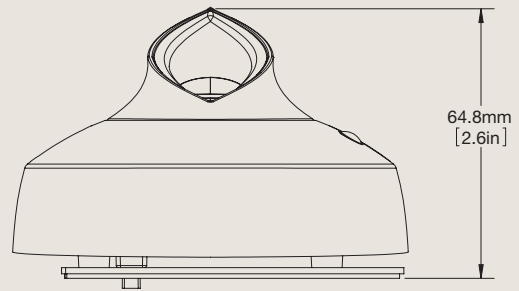

EC9103

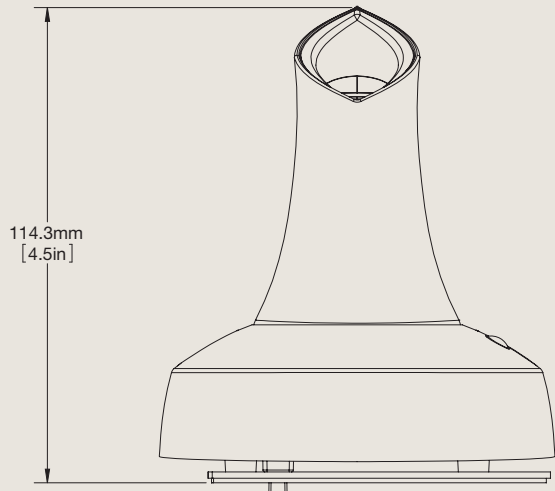

Base dimensions for the EC9102 and EC9103 are the same

One sensor can secure all handheld merchandise

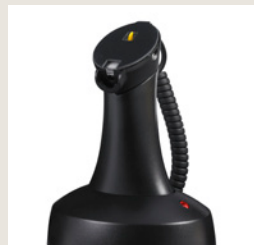

Series 940 Camera Stands have a long stretch, long life, low maintenance cord.



CORPORATE OFFICE // North America// 704.752.6513// 888.55.INVUE
EUROPEAN OFFICE // The Netherlands // +31.23.8900150
ASIAN OFFICE // Singapore // +65.6766.4844

invUE
 SECURITY PRODUCTS™

Transition from counter display to wall display in seconds.



Series 940 features lock-in power connectors for extra protection.



product ordering

ORDER CODE	DESCRIPTION	EXTERNAL DIM. (L x W x H)	CARTON QTY.	CARTON WT.
EC9102-W EC9102-B	Handheld Puck - White Handheld Puck - Black	4.0" L x 3.5" W x 3.3" H (10.1cm L x 8.9cm W x 8.3cm H)	1	0.55 lbs (0.24 kg)
EC9103-W EC9103-B	Handheld Stand - White Handheld Stand - Black	5.0" L x 3.8" W x 5.7" H (12.6cm L x 9.7cm W x 11.8cm H)	1	0.60 lbs (0.26 kg)
EC9123-W EC9123-B	Handheld Dual Sensor - White Handheld Dual Sensor - Black	12.0" L x 1.4" W x 1.2" H (30.5cm L x 3.5cm W x 3.1cm H)	1	0.10 lbs (0.04 kg)
EC9124-W EC9124-B	Handheld Single Sensor - White Handheld Single Sensor - Black	12.0" L x 1.4" W x 1.2" H (30.5cm L x 3.5cm W x 3.1cm H)	1	0.10 lbs (0.04 kg)
EC9127-W EC9127-B	Flex Cell Sensor Narrow Phone - White Flex Cell Sensor Narrow Phone - Black	12.0" L x 1.4" W x 1.2" H (30.5cm L x 3.5cm W x 3.1cm H)	1	0.10 lbs (0.04 kg)
EC9128-W EC9128-B	Flex Cell Sensor Wide Phone - White Flex Cell Sensor Wide Phone - Black	12.0" L x 1.4" W x 1.2" H (30.5cm L x 3.5cm W x 3.1cm H)	1	0.10 lbs (0.04 kg)
EC9150	5 Volt Power Supply - US	3.1" L x 2.6" W x 1.8" H (7.9cm L x 6.6cm W x 4.5cm H)	1	0.25 lbs (0.12 kg)
EC9151	5 Volt Power Supply - EUR	3.1" L x 2.6" W x 1.8" H (7.9cm L x 6.6cm W x 4.5cm H)	1	0.25 lbs (0.12 kg)
EC9152	5 Volt Power Supply - UK	3.1" L x 2.6" W x 1.8" H (7.9cm L x 6.6cm W x 4.5cm H)	1	0.25 lbs (0.12 kg)
EC9153	5 Volt Power Supply - AUS	3.1" L x 2.6" W x 1.8" H (7.9cm L x 6.6cm W x 4.5cm H)	1	0.25 lbs (0.12 kg)
EC9141	Single Sensor Replacement Adhesive - Black	8.0" L x 4.5" W x 0.3" H (20.3cm L x 11.4cm W x 0.6cm H)	20	0.20 lbs (0.09 kg)
EC9142	Dual Sensor Replacement Adhesive - Black	8.0" L x 4.5" W x 0.3" H (20.3cm L x 11.4cm W x 0.6cm H)	20	0.21 lbs (0.10 kg)
EC9149	Replacement Adhesive for Stand & Puck Base - Black	5.1" L x 8.3" W x 0.1" H (13.0cm L x 21.1cm W x 0.3cm H)	8	0.12 lbs (0.05 kg)
AF7425	Replacement Flex Cell Switches Narrow Phone	5.1" L x 8.3" W x 0.1" H (13.0cm L x 21.1cm W x 0.3cm H)	5	0.10 lbs (0.05 kg)
AF7426	Replacement Flex Cell Switches Wide Phone	5.1" L x 8.3" W x 0.1" H (13.0cm L x 21.1cm W x 0.3cm H)	5	0.10 lbs (0.05 kg)

Items required to create a powered display:

① Display Stand/Puck (listed above); ② Sensor; ③ Power Connector; ④ Standardized Power Supply

For additional information, please contact your local InVue sales representative, or consult the InVue Secure Displays Product Catalog, available online at invuesecurity.com/podscatalog.

CORPORATE OFFICE // North America // 704.752.6513 // 888.55.INVUE

EUROPEAN OFFICE // The Netherlands // +31.23.8900150

ASIAN OFFICE // Singapore // +65.6766.4844

inVUE
SECURITY PRODUCTS™

©2011 InVue Security Products. No endorsement of InVue products has been made by any of the manufacturers of the products shown. Product is sold pursuant to InVue's warranty which can be found at www.invuesecurity.com/english/warranty.html

invuesecurity.com
©2011 InVue Security Products